

SKYMASTER SERIES APS 250

THREE-AXIS POSITIONER, 250 kg CAPACITY



Technical data

Max. load (N)	2500
Rotation speed (rpm)	0,2-4,5
Max. rotational torque (Nm)	80
Tilting torque (Nm)	300
Tilting / angle (°)	man 135
Tilting time 0-max angle (s)	manual
Table plate diameter (mm)	400
T-slots on table plate	3x M10 DIN508
Center hole dia (mm)	60
Max.welding current (A)	350
Height min-max (mm)	490-920
Width (mm)	540
Length (mm)	950
Weight (kg)	170
Mains supply connection 50 Hz	1x230V+N+PE
Power (A)	16

Due to continuous R&D, Pemamek Ltd reserves the right to change the specification without notice.

PEMA SKYMASTER SERIES

PEMA Skymaster positioner for extra-heavy work. The height, tilt and rotating speed of work-piece are fully adjustable.

- Work-pieces can be set to the best possible welding positions. As a result welding productivity can be raised significantly.

- Hundreds of man-hours saved yearly compared to manual work-piece handling. With PEMA Skymaster these hours can be used on actual productive work.

- Always the optimal dimensions for your product on purposes. Standard selection from 250 kg up to 35,000 kg.

- Large movements - compact in size
- Motorized rotation
- Manual tilting and height adjustment
- Remote control for all functions
- Integration to other PEMA solutions
- Safety valves in hydraulic system
- Digital RPM-display
- Self-locking gears
- Extensive world-wide PEMA service
- Fast delivery and production start-up

BETTER PRODUCTIVITY

Lift , rotate or tilt the workpiece. Skymaster guarantees optimal working position, always.

IMPROVED QUALITY

Good ergonomics and safety secure welder's high motivation and working quality.

DESIGNED TO LAST

Engineered to endure even the most robust conditions. Partner that will not let you down.



Optional accessories

- Foot pedal for start/stop of rotation
- Foot pedal for speed control of rotation

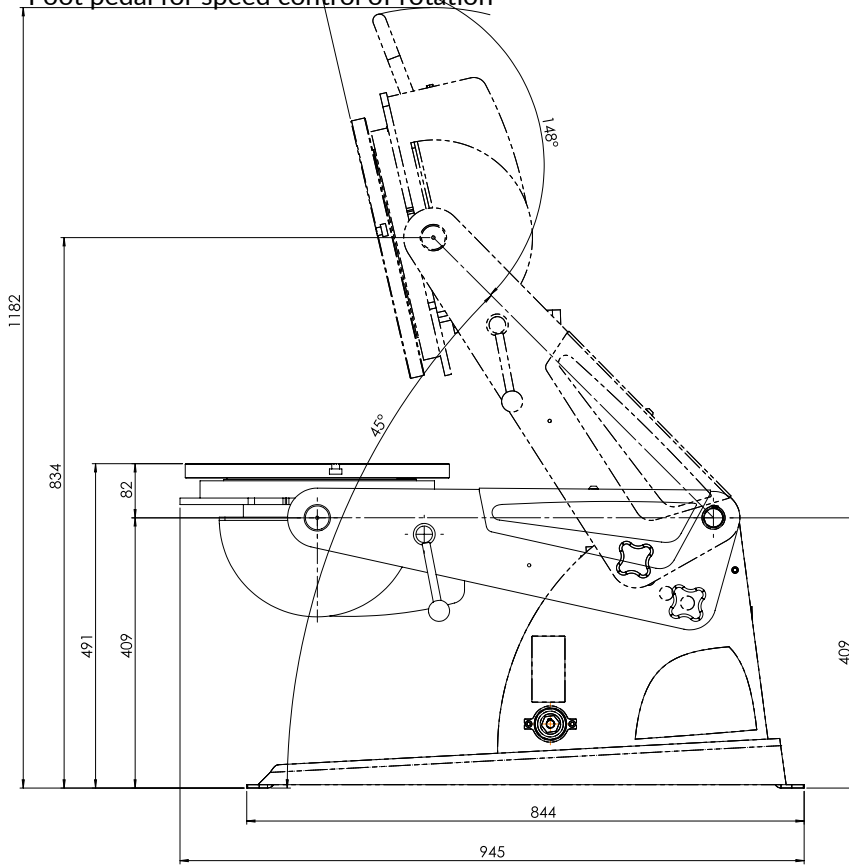

Wired remote included.

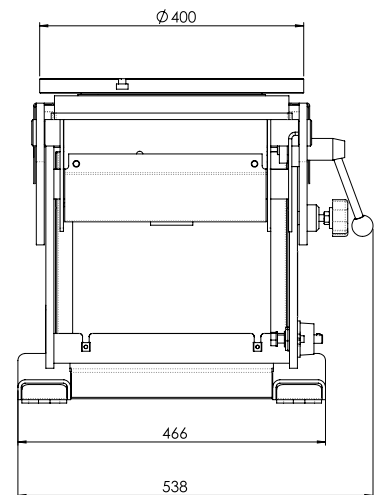

LOAD CAPACITY DIAGRAMS

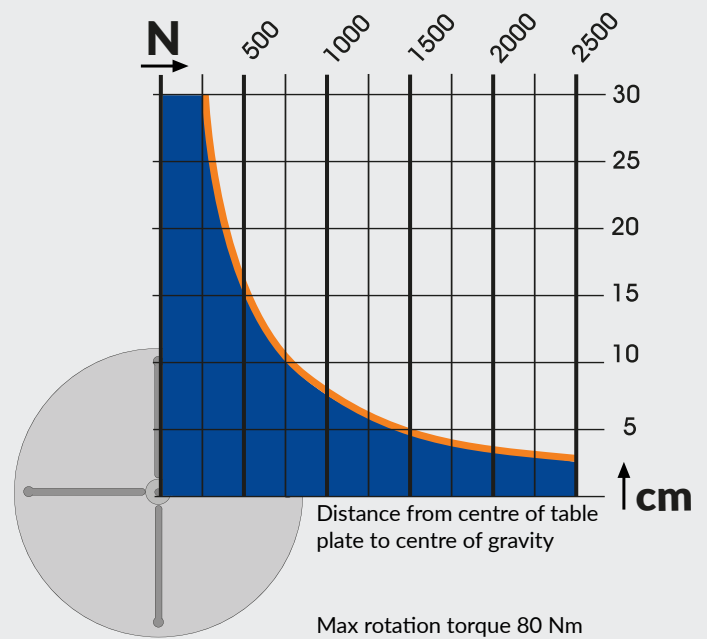
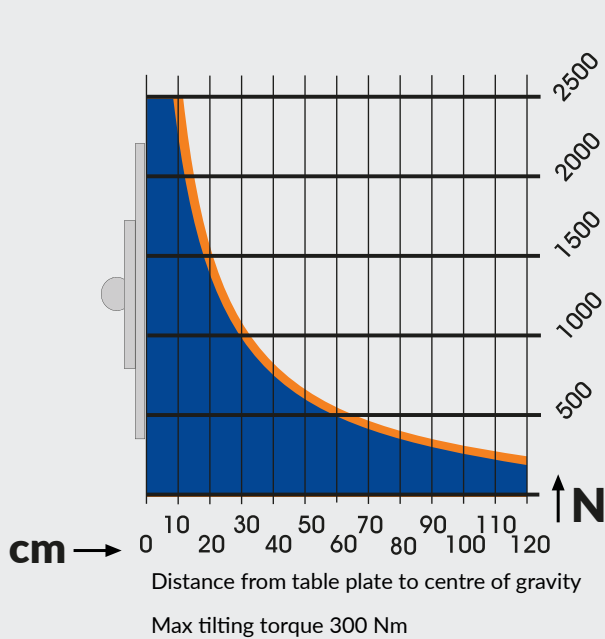

PEMAMEK LTD

Lamminkatu 47, FI-32200 Loimaa, Finland

Tel: +358 10 501 61

Email: info@pemamek.com www.pemamek.com