

PEMA APSi 35000

Skymaster PRO series - Making things easy.

Pema
WELDING AUTOMATION

PROGRAMMABLE – DIGITAL – VISUAL

PEMA Skymaster PRO positioner for extra-heavy work. The height, tilt and rotating speed of work piece are fully adjustable and programmable.

- Optimal and repeatable position for ergonomics, capacity increase and simulated movements for safety. As a result welding productivity can be raised significantly compared to conventional positioner.

- PRO features are available with mobile, tablet and laptop via WiFi. PRO application runs on internet browser and includes e.g. programming for the positioner, machine diagnostic, maintenance book and possibility to add notes.

- Hundreds of man-hours saved yearly compared to manual work-piece handling. With PEMA Skymaster PRO these hours can be used on actual productive work.

- Always the optimal dimensions for your product on purposes. Skymaster PRO series from 750 kg up to 35,000 kg.

Max. load (N)	350 000
Rotation speed (rpm)	0,02-0,4
Max. rotational torque (Nm)	55 000
Tilting torque (Nm)	280 000
Tilting / angle (°)	hydr / 120
Tilting time 0-max angle (s)	160
Table plate diameter (mm)	1950
T-slots on table plate	8x M24 DIN508
Integrated grounding, max. current (A)	2100
Height min-max (mm)	2000-3500
Width (mm)	2120
Length (mm)	4360
Weight (kg)	13 600
Main supply cable length (m)	12
Main supply connection 50 Hz	3x400VAC+(N)+PE
Power (A)	32

Due to continuous R&D, Pemamek Ltd reserves the right to change the specification without notice.

MORE PRODUCTIVITY

Save all positions, lifting, rotation and tilting and modify later if needed. Skymaster PRO guarantees optimal working position, always.

IMPROVED QUALITY

Good ergonomics and safety secure welder's high motivation and working quality.

DESIGNED TO LAST

Skymaster PRO positioners are engineered to endure even the most robust conditions. Partner that will not let you down.



- Always correct welding and assembly positions
- Visual programming for all movements
- Improved welding quality
- Broad hydraulic 3-axis movements
- Better working ergonomics
- Fast production start-up
- Integration to other PEMA solutions
- High-quality components
- Extensive world-wide PEMA service



MAIN MEASUREMENTS

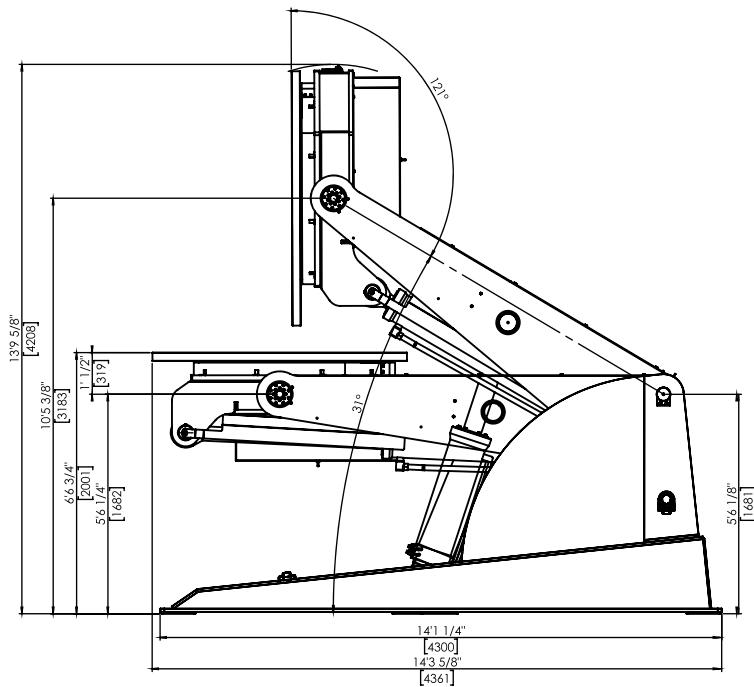

Durable, wired RC32H remote control included

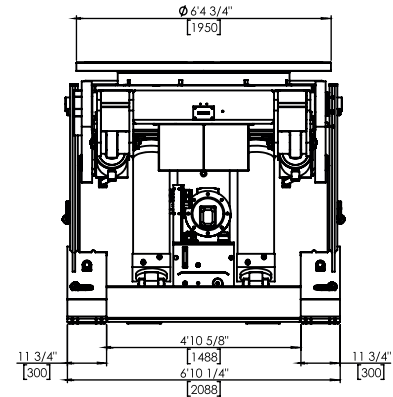

LOAD CAPACITY DIAGRAMS

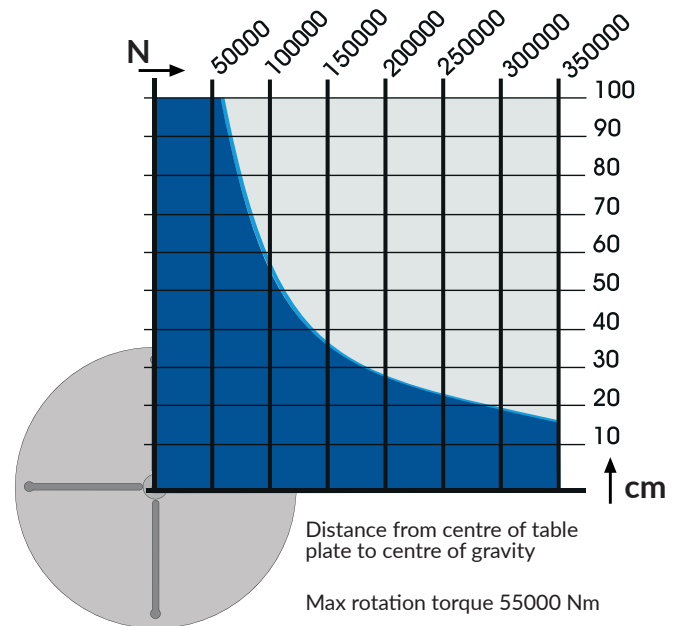
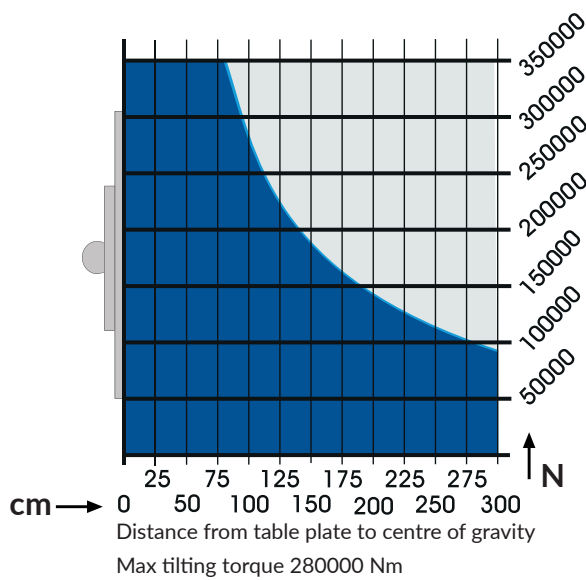

OPTIONS

- Tablet for PRO application
- Foot pedal for PRO features and start/stop of rotation in manual mode
- Foot pedal for PRO features and speed control of rotation in manual mode
- External control of rotation
- Wireless remote control



Pema
WELDING AUTOMATION

pemamek.com
@pemawelding



General fabrication
Heavy equipment
Offshore and process equipment

Power generation
Shipbuilding
Wind energy

